

Copyright © 2021 by Big Bike Parts, Inc. No part of this instruction sheet may be reproduced without the written permission of Big Bike Parts, Inc.

PART NO. 41-416

DRIVER BACKREST

7/12/2021

FITMENT: CAN AM RYKER 2019-NEWER

TOOLS NEEDED: T30 TORX

10MM WRENCH

4MM ALLEN WRENCH

REMOVABLE THREAD LOCK

5MM ALLEN WRENCH

**PLEASE READ THROUGH AND UNDERSTAND THESE INSTRUCTIONS BEFORE BEGINNING. \*USE REMOVABLE THREAD LOCK ON ALL FASTENERS\***  
**ESTIMATED INSTALLATION TIME: 30 TO 60 MIN.**

**INSTALLATION WITHOUT MAX MOUNT INSTALLED:**

- 1A. USING A T25 REMOVE THE 6 SCREWS SHOWN IN FIG. 1A. (LH SIDE CAP SCREWS ARE OPPOSITE OF RH SIDE CAP SCREWS) REMOVE BOTH SIDE CAPS AND THE REAR SPOILER FROM THE BIKE. **NOTE: IF YOU HAVE THE SHAD BAG MOUNT INSTALLED, IT WILL NEED TO BE UNINSTALLED BEFORE REMOVING THE REAR SPOILER. STEPS 2A THROUGH 5A ARE OPTIONAL IF YOU WISH TO USE THE REAR SPOILER.**
- 2A. PLACE A PIECE OF MASKING TAPE ON THE REAR SPOILER AND MARK THE RECTANGLE LINES TO CUT. (FIG. 2A)
- 3A. CAREFULLY CUT THROUGH BOTH LAYERS OF THE REAR SPOILER. BE SURE TO REMOVE ANY SHARP EDGES FROM CUTTING.
- 4A. INSTALL THE REAR SPOILER, LH SIDE CAP AND RH SIDE CAP IN REVERSE ORDER AND TIGHTEN THE 6 SCREWS FROM STEP 1. **BE SURE NOT TO OVER TIGHTEN THE SCREWS.**
- 5A. CONTINUE TO THE STEPS BELOW FOR THE REST OF THE BACKREST INSTALL.

**INSTALLATION WITH MAX MOUNT INSTALLED:**

1. USE A T30 TORX TO REMOVE THE TWO OEM SEAT SCREWS SHOWN IN FIG. 1 LOCATED UNDER THE SEAT (THESE SCREWS WILL NOT BE REUSED).
2. REMOVE THE BACKREST BASE MOUNT AND THE BACKREST RISER FROM THE PACKAGE (FIG. 2).
3. PLACE A SMALL DROP OF REMOVABLE THREAD LOCK TO THE ENDS OF THE TWO M8 X 14MM LONG SCREWS AND INSTALL THEM INTO THE BASE MOUNT AS SHOWN IN FIG. 2. DO NOT TIGHTEN YET. **NOTE: THERE ARE TWO HEIGHT POSITIONS. USE THE TOP TWO HOLES IN THE BASE MOUNT FOR A TALLER BACKREST, USE THE BOTTOM TWO HOLES FOR A LOWER BACKREST FIG. 2 SHOWS THE LOWER POSITION.**
4. INSTALL THE SUPPLIED RISER IN PLACE ON THE TWO SCREWS AS SHOWN IN FIG. 2. USING A 5MM ALLEN WRENCH, ADJUST AND TIGHTEN THE SCREWS SO THAT THE HEAD OF THE SCREW IS AS CLOSE AS POSSIBLE TO THE RISER BUT THE RISER WILL STILL SLIDE OFF OF THE SCREWS.
5. PLACE THE BACKREST BASE MOUNT IN POSITION UNDER THE SEAT AND INSTALL THE TWO M6 X 25MM SOCKET HEAD SCREWS AND LOCK WASHERS IN THE HOLES THAT YOU REMOVED THE SCREWS IN STEP 1 (FIG. 3). **FINGER TIGHTEN ONLY, DO NOT TIGHTEN COMPLETELY.**
6. INSTALL TWO M8 X 40MM BUTTON HEAD SCREWS, FLAT WASHERS, SPACERS AND NYLOCK NUTS ACCORDING TO FIG. 3. TIGHTEN THESE COMPLETELY WHILE PUSHING THE BASE MOUNT UP TIGHT UNDER THE FRAME/SEAT. **NOTE: IF YOU HAVE A SHAD BAG MOUNT INSTALLED, THE TWO SCREWS AND CLIP NUTS MUST BE REMOVED BEFORE INSTALLING THE M8 X 40MM SCREWS.**
7. FINISH TIGHTENING THE TWO SCREWS FROM STEP 5. **DO NOT OVER TIGHTEN SCREWS.**
8. REMOVE THE REST OF THE PARTS FROM THE PACKING.
9. ASSEMBLE THE BACKREST RISER ACCORDING TO FIG. 4.
10. ASSEMBLE THE BACKREST AND INSTALL ONTO THE BACKREST RISER ASSEMBLY (FIG. 4).
11. INSTALL THE M8 X 14MM SCREWS IN THE MOUNT BASE ACCORDING TO FIG. 5. **(BE SURE TO LEAVE ENOUGH OF A GAP SO THE RISER WILL SLIDE ONTO THE M8 BOLTS.)**
12. INSTALL THE BACKREST ASSEMBLY ONTO THE MOUNT BASE AS SHOWN IN FIG. 6.

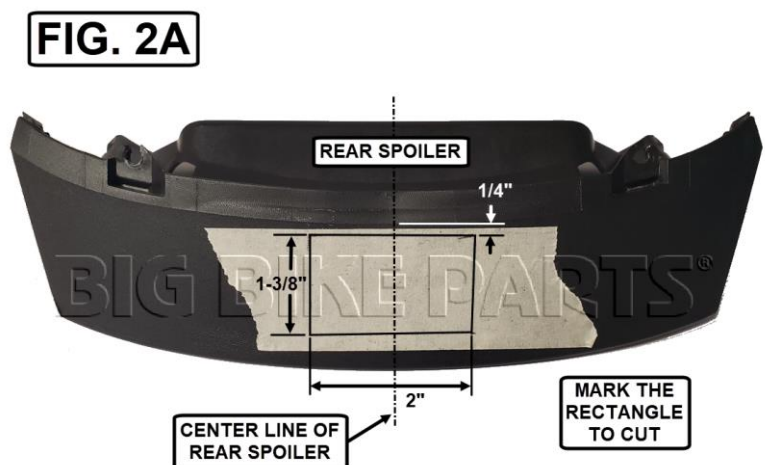
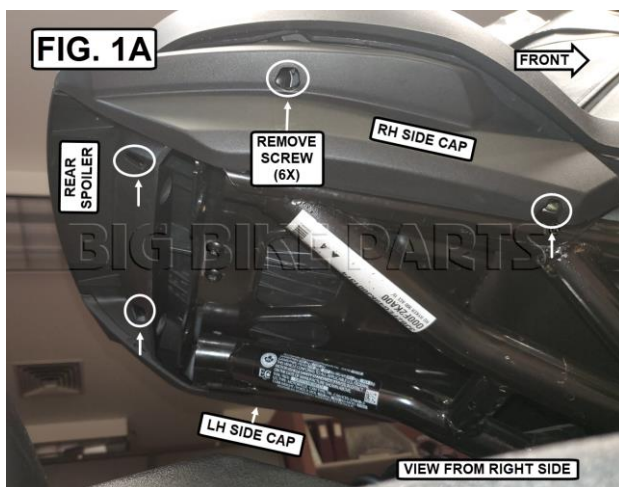

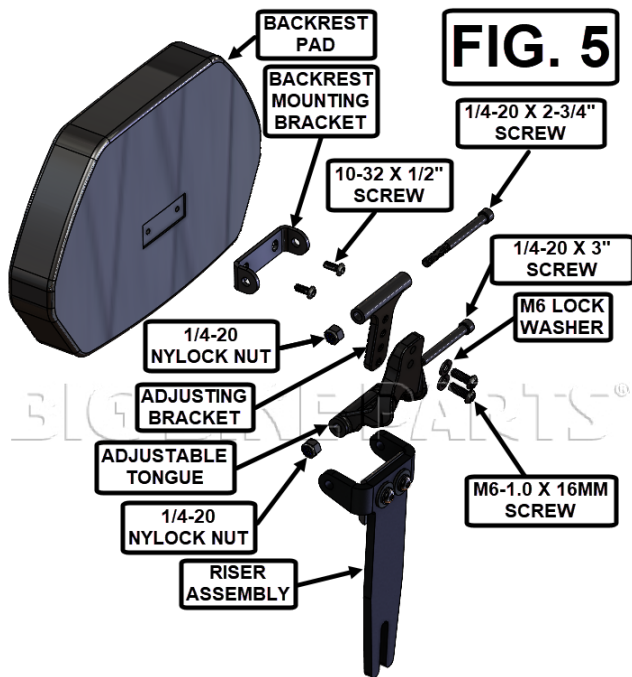
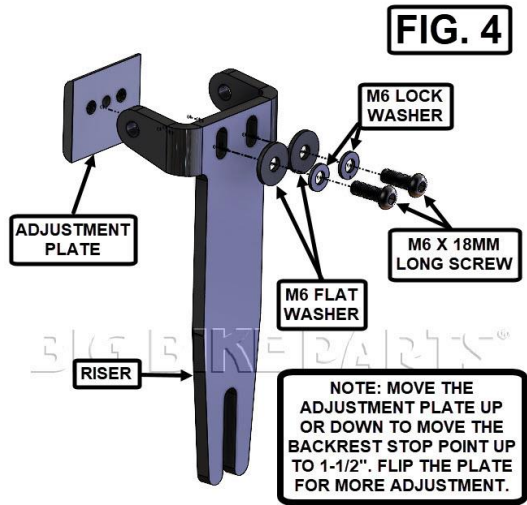
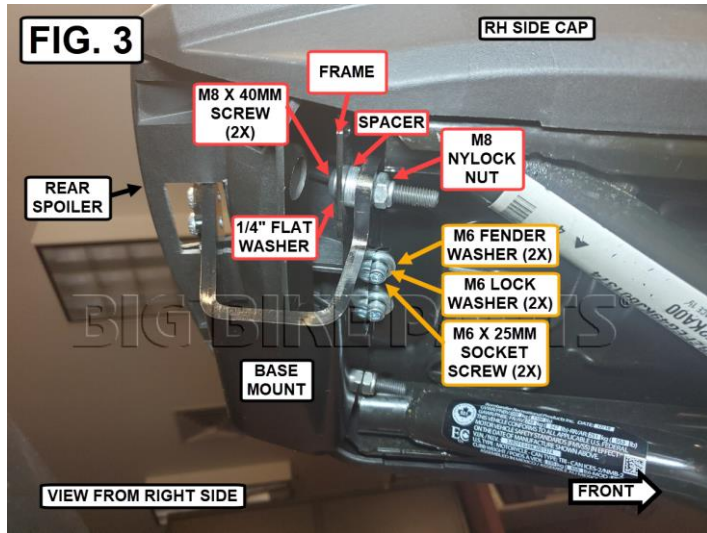
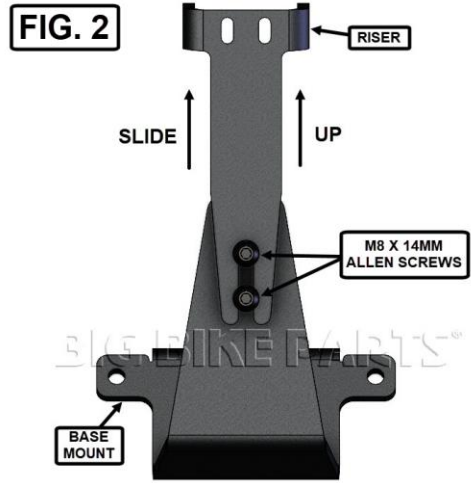
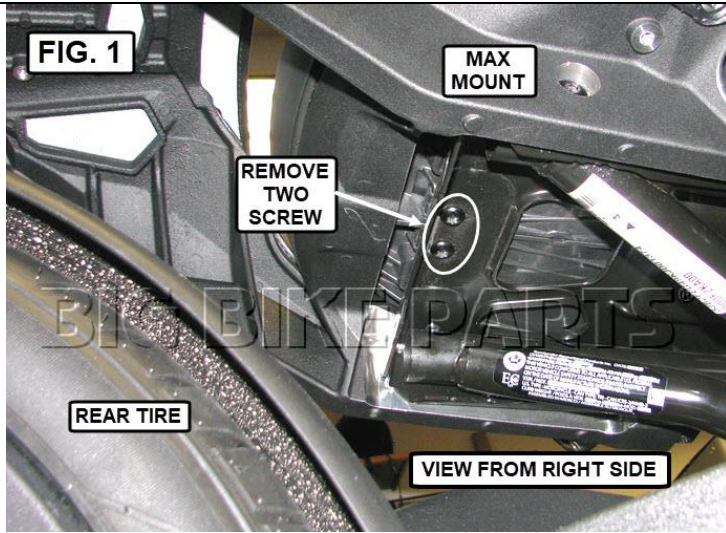

**WARNING**

BACKREST IS DESIGNED TO SUPPORT RIDERS LOWER BACK WHEN RIDING. DO NOT APPLY EXCESSIVE FORCE BY PUSHING BACK WITH YOUR FULL BODY WEIGHT. DO NOT USE BACKREST TO LIFT OR SUPPORT MOTORCYCLE.

**NOTICE**

IGNORING THE CONTENTS OF THESE INSTRUCTIONS MAY AFFECT THE PRODUCT PERFORMANCE AND FUNCTIONALITY. NOT FOLLOWING THESE INSTRUCTION MAY CAUSE DAMAGE TO THE PRODUCT OR THE VEHICLE TO WHICH IT IS BEING ATTACHED.